

# FAST SERVICE

**MANUFACTURE IN MAX.  
10 WORKING DAYS!**

plus shipping time

## EB 80

SINGLE-FLUTED GUN DRILLS  
EB 80 BRIGHT OR COATED!

Your tailor-made single-fluted gun drills within a few working days:  
Gühring's super quick gun drill offer makes it possible.  
Special tools within 10 working days!

### DESIGN OPTIONS

- **!** nominal diameter  $\varnothing$  2.0 – 14.9 mm increasing by 0.1 mm
- **!** nominal diameter  $\varnothing$  15.0 – 24.5 increasing by 0.5 mm
- **!** nominal diameter  $\varnothing$  25.0 – 30.0 mm increasing by 1 mm
- in addition inch dimensions and special dimensions on request
- standard geometry AB-001
- total length up to bis 2.000 mm
- standard driver
- carbide grade K15
- head form G and C (head form C starting from nominal diameter of  $\varnothing$  4.0 mm)
- bright or in combination with standard coating
- option with lateral chip breaker for long-chipping steels  
(AB-002 starting from nominal diameter of  $\varnothing$  4.0 mm and manufacture within max. 15 working days)

**!** All gun drills must have support for the pilot hole.  
**!** Gun drills must never operate at full speed without support in the machine shop.

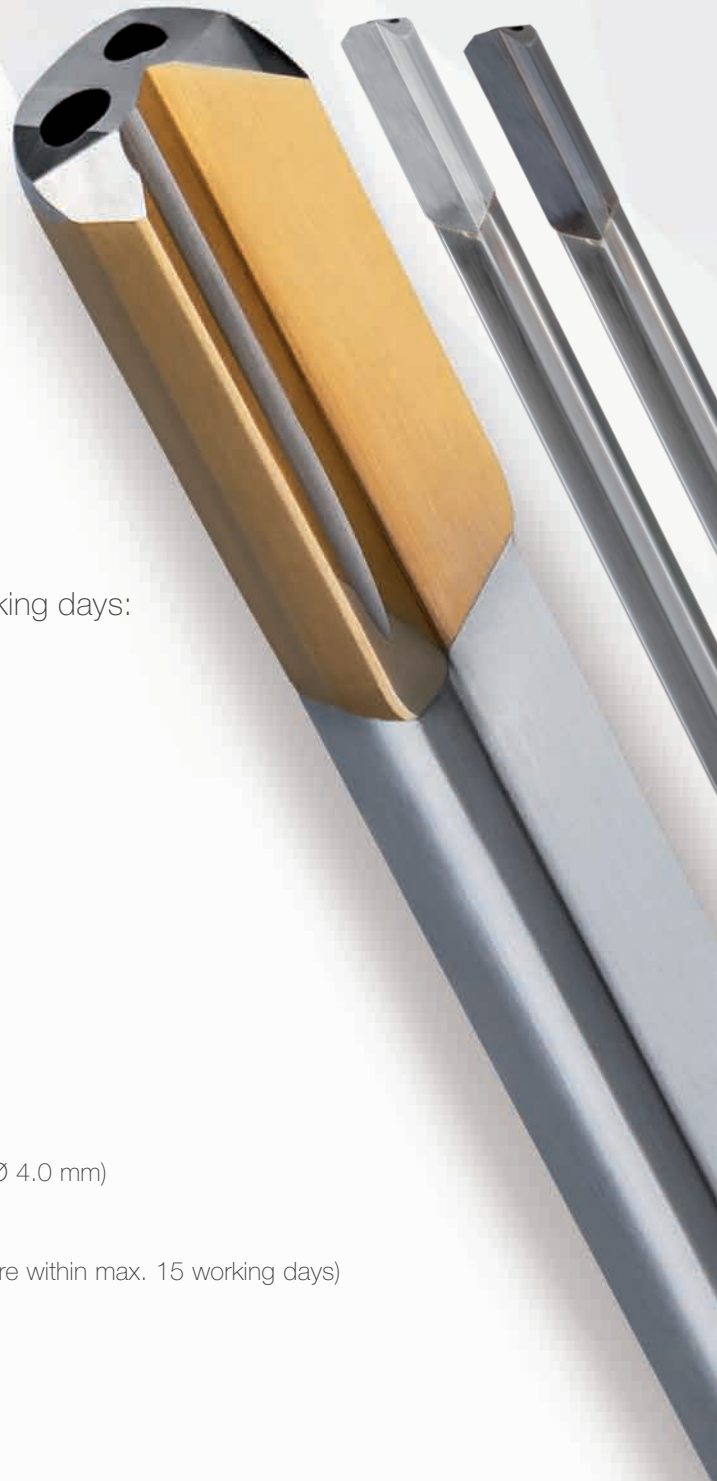

## IN ONLY FOUR STEPS TO THE CORRECT TOOL:

**1**



**NOM.-Ø**  
Please choose  
a diameter from the gun drill  
quick service list

**2**

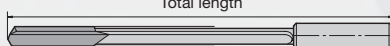

**TOTAL LENGTH**  
Please choose  
a total length up to max. 2,000 mm  
(length determination see below)

**3**

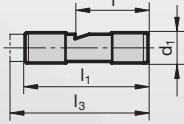

**DRIVER**  
Please choose  
a valid driver\*

**4**

Surface	Material
TIN →	<b>P</b> Steel
nanoA →	<b>M</b> Stainless steel
Signum →	<b>K</b> Cast iron
blank →	<b>N</b> Aluminium
FIRE →	<b>S</b> Special alloy
SuperA →	<b>H</b> Hardened steel

**SURFACE**  
Please choose  
one of the surface finish  
options below

The EB 80 gun drill quick service promotion only applies to gun drills that

- fit in the described grid. The head length, the taper of the head, flute length and other technical details are determined in line with our Gühring standard.
- have one of the surface finish options below. Other coating options (i.e. TiCN) can have a longer delivery time.
- have all necessary components available in stock in the required quantity.

## SINGLE-FLUTED GUN DRILLS EB 80 BRIGHT OR COATED MANUFACTURE IN MAX. 10 WORKING DAYS!

Enquiry    Order   Items \_\_\_\_\_   Enquiry/order returned to us by fax or e-mail.

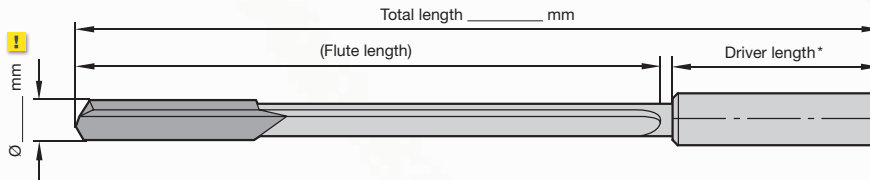

### DRIVER \*

no    Code no.: \_\_\_\_\_

### GEOMETRY

Standard AB-001    Lateral chip breaker AB-002  
(from nominal diameter Ø 4.0 mm)

### HEAD FORM

G    C

### SURFACE

bright    TiN    TiAlN    TiAlN-nanoA    TiAlN-SuperA    FIRE    nanoFIRE    Signum    Endurum

\* Detailed information on our driver programme can be found in our Deep hole drilling tool catalogue or Drilling tool catalogue. These are available to be downloaded at [www.guehring.com](http://www.guehring.com) or on request.

Customer no./name, first name

Company

Department

Telephone

Fax

Email

Date/signature

**Gühring KG**

P.O. Box 100247 • 72423 Albstadt • Herderstrasse 50-54 • 72458 Albstadt • Germany  
T +49 74 31 17-0 • F +49 74 31 17-21 279 • [info@guehring.de](mailto:info@guehring.de) • [www.guehring.com](http://www.guehring.com)